



High power cycling capability  
Low on-state and switching losses  
Designed for traction and industrial applications

## Phase Control Thyristor Type T163-1600-28

Mean on-state current	$I_{TAV}$	1600 A			
Repetitive peak off-state voltage	$V_{DRM}$	2000 ÷ 2800 V			
Repetitive peak reverse voltage	$V_{RRM}$				
Turn-off time	$t_q$	320 $\mu$ s			
$V_{DRM}, V_{RRM}, V$	2000	2200	2400	2600	2800
Voltage code	20	22	24	26	28
$T_j, ^\circ C$	- 60 ÷ 125				

### MAXIMUM ALLOWABLE RATINGS

Symbols and parameters		Units	Values	Test conditions	
<b>ON-STATE</b>					
$I_{TAV}$	Mean on-state current	A	1600 2120	$T_c = 99^\circ C$ , Double side cooled $T_c = 85^\circ C$ , Double side cooled 180° half-sine wave; 50 Hz	
$I_{TRMS}$	RMS on-state current	A	2512	$T_c = 99^\circ C$ , Double side cooled 180° half-sine wave; 50 Hz	
$I_{TSM}$	Surge on-state current	kA	38.0 44.0	$T_j = T_{jmax}$ $T_j = 25^\circ C$	180° half-sine wave; 50 Hz ( $t_p = 10$ ms); single pulse; $V_D = V_R = 0$ V; Gate pulse: $I_G = 2$ A; $t_{GP} = 50 \mu$ s; $di_G/dt \geq 1$ A/ $\mu$ s
			40.0 46.0	$T_j = T_{jmax}$ $T_j = 25^\circ C$	180° half-sine wave; 60 Hz ( $t_p = 8.3$ ms); single pulse; $V_D = V_R = 0$ V; Gate pulse: $I_G = 2$ A; $t_{GP} = 50 \mu$ s; $di_G/dt \geq 1$ A/ $\mu$ s
$I^2t$	Safety factor	$A^2s \cdot 10^3$	7220 9680	$T_j = T_{jmax}$ $T_j = 25^\circ C$	180° half-sine wave; 50 Hz ( $t_p = 10$ ms); single pulse; $V_D = V_R = 0$ V; Gate pulse: $I_G = 2$ A; $t_{GP} = 50 \mu$ s; $di_G/dt \geq 1$ A/ $\mu$ s
			6640 8780	$T_j = T_{jmax}$ $T_j = 25^\circ C$	180° half-sine wave; 60 Hz ( $t_p = 8.3$ ms); single pulse; $V_D = V_R = 0$ V; Gate pulse: $I_G = 2$ A; $t_{GP} = 50 \mu$ s; $di_G/dt \geq 1$ A/ $\mu$ s
<b>BLOCKING</b>					
$V_{DRM}, V_{RRM}$	Repetitive peak off-state and Repetitive peak reverse voltages	V	2000 ÷ 2800	$T_{jmin} < T_j < T_{jmax}$ ; 180° half-sine wave; 50 Hz; Gate open	
$V_{DSM}, V_{RSM}$	Non-repetitive peak off-state and Non-repetitive peak reverse voltages	V	2100 ÷ 2900	$T_{jmin} < T_j < T_{jmax}$ ; 180° half-sine wave; 50 Hz; single pulse; Gate open	
$V_D, V_R$	Direct off-state and Direct reverse voltages	V	$0.75 \cdot V_{DRM}$ $0.75 \cdot V_{RRM}$	$T_j = T_{jmax}$ ; Gate open	

<b>TRIGGERING</b>				
$I_{FGM}$	Peak forward gate current	A	8	$T_j = T_{j\max}$
$V_{RGM}$	Peak reverse gate voltage	V	5	
$P_G$	Gate power dissipation	W	5	$T_j = T_{j\max}$ for DC gate current
<b>SWITCHING</b>				
$(di_T/dt)_{crit}$	Critical rate of rise of on-state current non-repetitive (f=1 Hz)	A/ $\mu$ s	630	$T_j = T_{j\max}$ ; $V_D = 0.67 \cdot V_{DRM}$ ; $I_{TM} = 2 I_{TAV}$ ; Gate pulse: $I_G = 2$ A; $t_{GP} = 50 \mu$ s; $di_G/dt \geq 1$ A/ $\mu$ s
<b>THERMAL</b>				
$T_{stg}$	Storage temperature	$^{\circ}$ C	-60 ÷ 125	
$T_j$	Operating junction temperature	$^{\circ}$ C	-60 ÷ 125	
<b>MECHANICAL</b>				
F	Mounting force	kN	33.0 ÷ 40.0	
a	Acceleration	m/s <sup>2</sup>	50 100	Device unclamped Device clamped

## CHARACTERISTICS

Symbols and parameters		Units	Values	Conditions	
<b>ON-STATE</b>					
$V_{TM}$	Peak on-state voltage, max	V	1.75	$T_j = 25 \text{ }^{\circ}$ C; $I_{TM} = 5000$ A	
$V_{T(TO)}$	On-state threshold voltage, max	V	0.85	$T_j = T_{j\max}$ ;	
$r_T$	On-state slope resistance, max	m $\Omega$	0.200	$0.5 \pi I_{TAV} < I_T < 1.5 \pi I_{TAV}$	
$I_L$	Latching current, max	mA	1500	$T_j = 25 \text{ }^{\circ}$ C; $V_D = 12$ V; Gate pulse: $I_G = 2$ A; $t_{GP} = 50 \mu$ s; $di_G/dt \geq 1$ A/ $\mu$ s	
$I_H$	Holding current, max	mA	300	$T_j = 25 \text{ }^{\circ}$ C; $V_D = 12$ V; Gate open	
<b>BLOCKING</b>					
$I_{DRM}, I_{RRM}$	Repetitive peak off-state and Repetitive peak reverse currents, max	mA	200	$T_j = T_{j\max}$ ; $V_D = V_{DRM}$ ; $V_R = V_{RRM}$	
$(dv_D/dt)_{crit}$	Critical rate of rise of off-state voltage <sup>1)</sup> , min	V/ $\mu$ s	1000	$T_j = T_{j\max}$ ; $V_D = 0.67 \cdot V_{DRM}$ ; Gate open	
<b>TRIGGERING</b>					
$V_{GT}$	Gate trigger direct voltage, max	V	5.00	$T_j = T_{j\min}$ $T_j = 25 \text{ }^{\circ}$ C $T_j = T_{j\max}$	$V_D = 12$ V; $I_D = 3$ A; Direct gate current
			3.00		
			2.00		
$I_{GT}$	Gate trigger direct current, max	mA	500	$T_j = T_{j\min}$ $T_j = 25 \text{ }^{\circ}$ C $T_j = T_{j\max}$	
			300		
			200		
$V_{GD}$	Gate non-trigger direct voltage, min	V	0.35	$T_j = T_{j\max}$ ; $V_D = 0.67 \cdot V_{DRM}$ ;	
$I_{GD}$	Gate non-trigger direct current, min	mA	15.00	Direct gate current	
<b>SWITCHING</b>					
$t_{gd}$	Delay time	$\mu$ s	4.00	$T_j = 25 \text{ }^{\circ}$ C; $V_D = 0.4 \cdot V_{DRM}$ ; $I_{TM} = I_{TAV}$ ; Gate pulse: $I_G = 2$ A; $t_{GP} = 50 \mu$ s; $di_G/dt \geq 1$ A/ $\mu$ s	
$t_q$	Turn-off time <sup>2)</sup> , max	$\mu$ s	400	$dv_D/dt = 50$ V/ $\mu$ s; $T_j = T_{j\max}$ ; $I_{TM} = 2000$ A; $di_R/dt = -10$ A/ $\mu$ s; $V_R = 100$ V; $V_D = 0.67 V_{DRM}$ ;	

<b>THERMAL</b>					
$R_{thjc}$	Thermal resistance, junction to case, max	°C/W	0.0100	Direct current	Double side cooled
$R_{thjc-A}$			0.0220		Anode side cooled
$R_{thjc-K}$			0.0180		Cathode side cooled
$R_{thck}$	Thermal resistance, case to heatsink, max	°C/W	0.0030	Direct current	
<b>MECHANICAL</b>					
w	Weight, typ	g	1000		
$D_s$	Surface creepage distance	mm (inch)	36.50 (1.437)		
$D_a$	Air strike distance	mm (inch)	16.5 (0.650)		

### **PART NUMBERING GUIDE**

T	163	1600	28	N
1	2	3	4	5

1. Phase Control Thyristor
2. Design version
3. Mean on-state current, A
4. Voltage code
5. Ambient conditions: N – normal; T – tropical

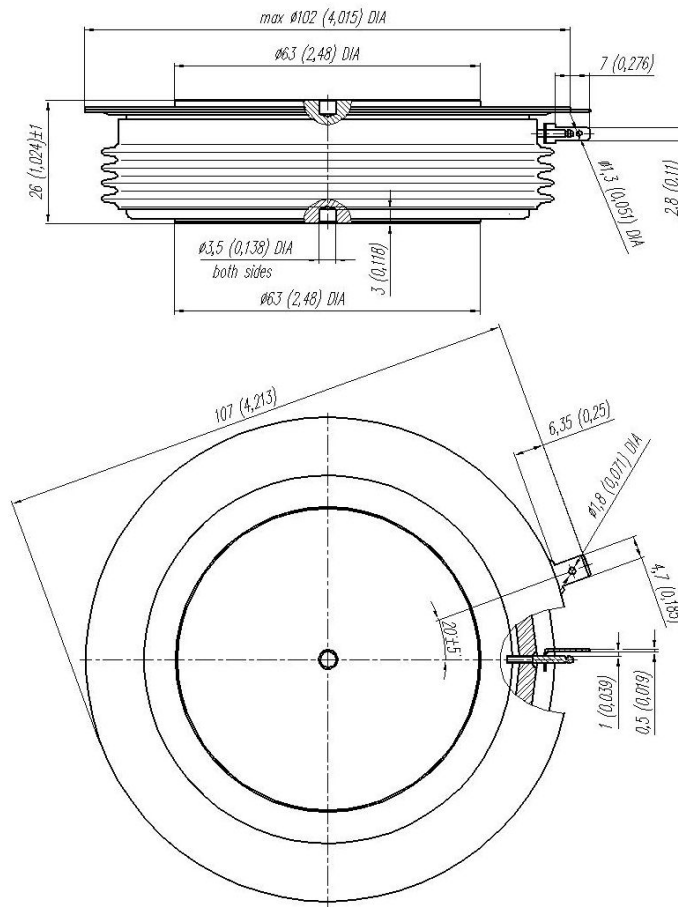

All dimensions in millimeters (inches)